



Accessory Fitting Instructions

Quickshifter Kit	
Kit Number	Models Affected
A9930428	Speed Triple S up to VIN 867684, Speed Triple R from VIN 735337
A9930469	Speed Triple S from VIN 867685, Speed Triple RS

Thank you for choosing this Triumph genuine accessory kit. This accessory kit is the product of Triumph's use of proven engineering, exhaustive testing, and continuous striving for superior reliability, safety and performance.

Completely read all of these instructions before commencing the installation of the accessory kit in order to become thoroughly familiar with the kit's features and the installation process.

These instructions should be considered a permanent part of your accessory kit, and should remain with it even if your accessory equipped motorcycle is subsequently sold.

Parts Supplied

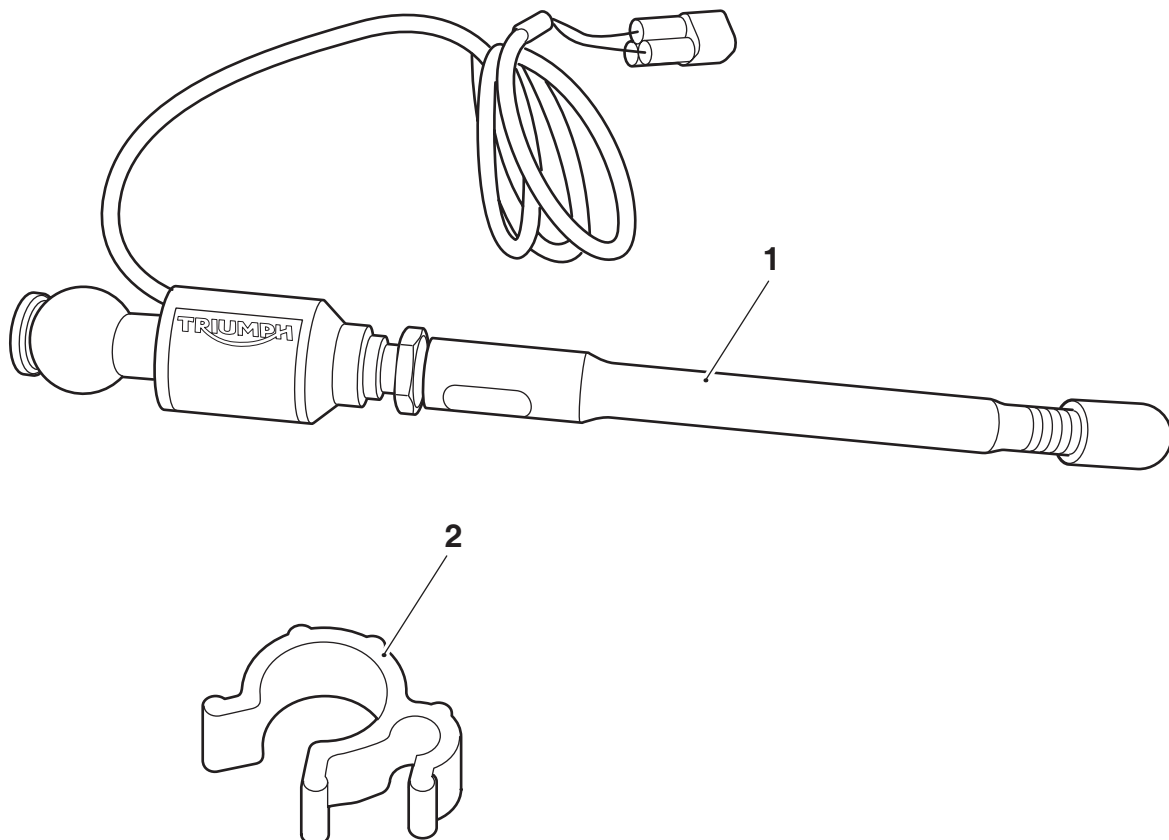

1. Quickshifter assembly	1 off	2. Cable clip	1 off
--------------------------	-------	---------------	-------

Warning

The accessory kits covered in this instruction are designed for use on specific models of Triumph motorcycle. The accessory kits and the models applicable are listed at the start of the instruction. They should not be fitted to any other Triumph model or to any other manufacturer's motorcycle. Fitting an accessory kit to a Triumph model not listed, or to any other manufacturer's motorcycle will affect the performance, stability and handling of the motorcycle. This may affect the rider's ability to control the motorcycle and could cause an accident.

Warning

Always have Triumph approved parts, accessories and conversions fitted by a trained technician of an authorised Triumph dealer. The fitment of parts, accessories and conversions by a technician who is not of an authorised Triumph dealer may affect the handling, stability or other aspects of the motorcycle's operation which may result in loss of motorcycle control and an accident.

Warning

Throughout this operation, ensure that the motorcycle is stabilised and adequately supported to prevent risk of injury from the motorcycle falling.

Warning

A torque wrench of known accurate calibration must be used when fitting this accessory kit. Failure to tighten any of the fasteners to the correct torque specification may affect motorcycle performance, handling and stability. This may result in loss of motorcycle control and an accident.

Note:

- Triumph offers a broad range of approved genuine accessories for your motorcycle. We cannot therefore cover all possible equipment variations in these instructions. For removal and installation of Triumph Genuine Accessories, always refer to the instructions supplied with the respective accessory kit. To obtain additional copies of any Triumph accessory instructions, visit www.triumphinstructions.com or contact your authorised Triumph dealer.

1. Remove the front panel from the fuel tank, as described in the Service Manual.
2. Disconnect the battery, negative (black) lead first.
3. Remove the seat, as described in the Service Manual.
4. Remove the fuel tank, as described in the Service Manual.
5. Remove the wire clips retaining the original gear selector rod front and rear ball joints, as shown. Retain the wire clips for re-use.

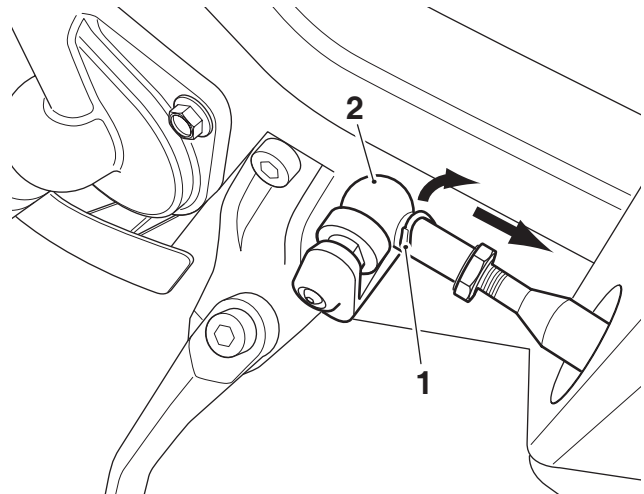

FRONT

1. Wire clip
2. Ball joint

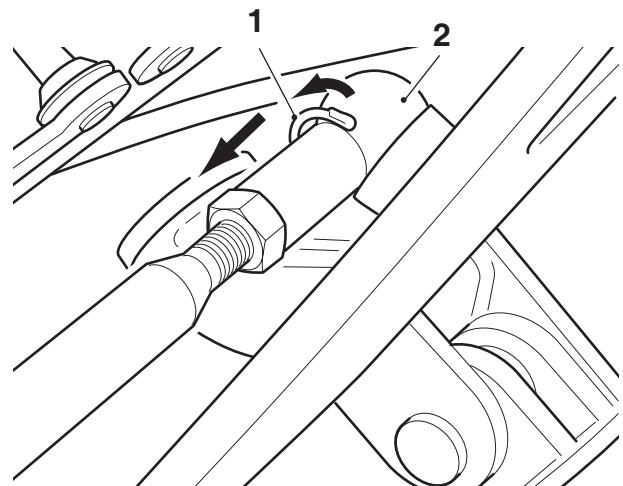

REAR

1. Wire clip
2. Ball joint
6. Remove the original gear selector rod from the motorcycle.



Caution

It may be difficult to remove the ball joint from the original gear selector rod. Do not use excessive force. If necessary, apply a releasing oil to the ball joint to aid removal.

7. Remove the rear ball joint and lock nut from the gear selector rod. Retain the lock nut and ball joint for re-use. Retain the gear selector rod if the motorcycle is to be returned to its original condition.
8. Remove the plastic end cap from the Quickshifter assembly selector rod.
9. Screw the original lock nut and ball joint, removed from the original gear selector rod, onto the Quickshifter assembly selector rod, as shown.

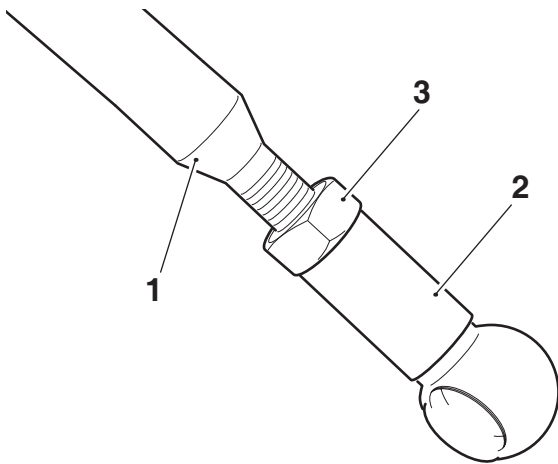

1. Quickshifter assembly selector rod
2. Ball joint, left hand thread
3. Lock nut, left hand thread

Note:

10. The initial setting of the Quickshifter assembly is different for specific models. Follow the appropriate setting procedure below.

Speed Triple S up to VIN 867684, Speed Triple R from VIN 735337

11. Adjust the position of the ball joint on the selector rod to 141.3 mm from the quickshifter ball joint, ensuring the orientation of ball joints is the same, as shown below. Finger tighten the lock nut at this stage.

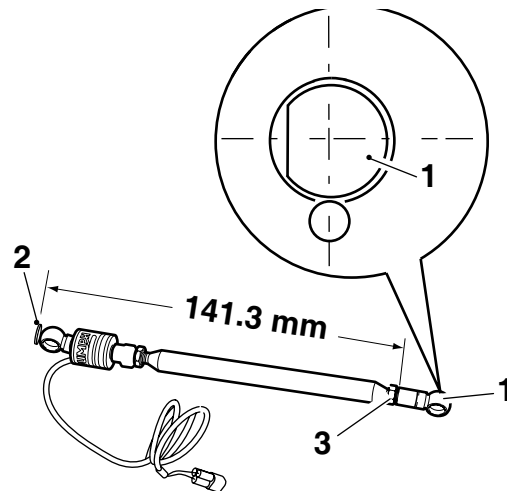

1. Ball joint, selector rod
2. Flat face, ball joint - Quickshifter sensor body
3. Lock nut

Speed Triple S from VIN 867685, Speed Triple RS

12. Adjust the position of the ball joint on the selector rod to 146.7 mm from the quickshifter ball joint, ensuring the orientation to the ball joints is the same, as shown below. Finger tighten the lock nut at this stage.

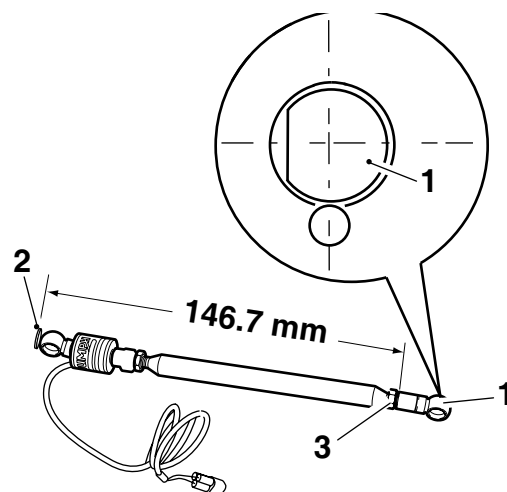

1. Ball joint, selector rod
2. Flat face, ball joint - Quickshifter sensor body
3. Lock nut

All Models

13. Locate the Quickshifter assembly in position through the frame with the sensor body at the front and the cable at the bottom. Route the cable up and over the transmission linkage, as shown.

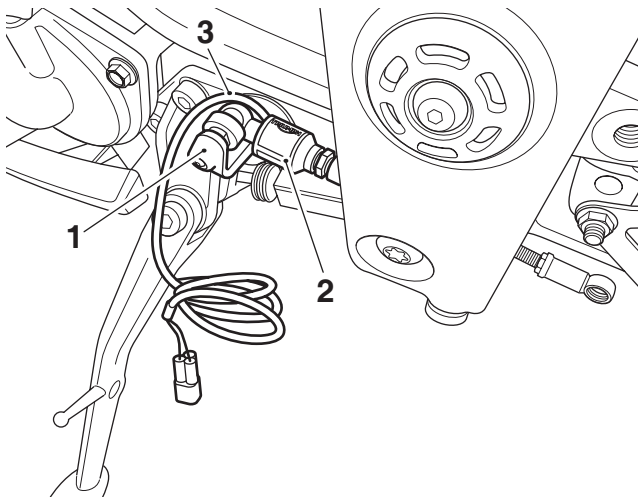

1. Transmission linkage
2. Sensor body
3. Cable

14. Attach the Quickshifter ball joint to the transmission linkage.

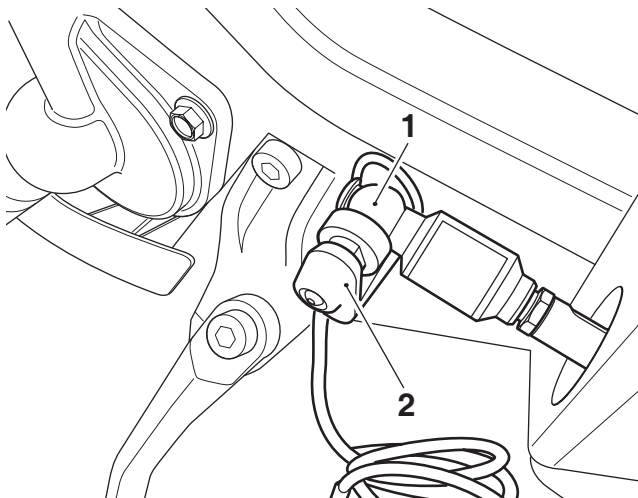

1. Quickshifter ball joint
2. Transmission linkage

15. Attach the rear ball joint to the foot control.

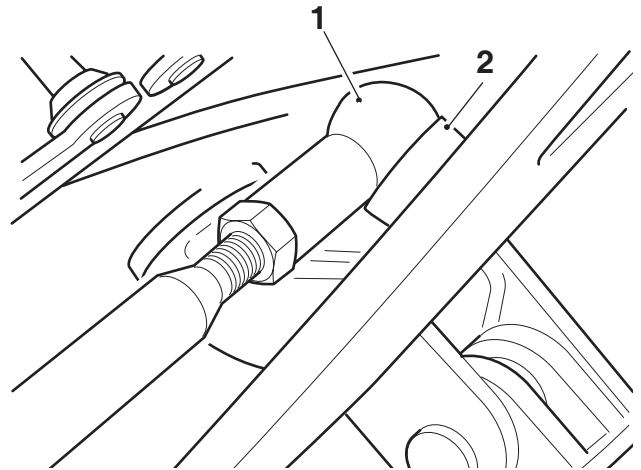

1. Ball joint
2. Foot control

16. Refit the wire clips to retain the ball joints. Ensure the wire clips locate correctly in the ball joints, before rotating the clips to lock in place.

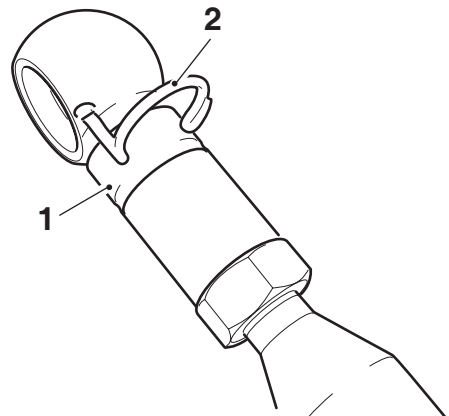

1. Ball joint
2. Wire clip

17. Tighten the lock nut against the ball joint on the rear of the Quickshifter assembly to **4 Nm**.

18. Remove the bracket from the left hand side of the motorcycle, as shown below. Retain the bracket, screws and plastic fixings for re-use.

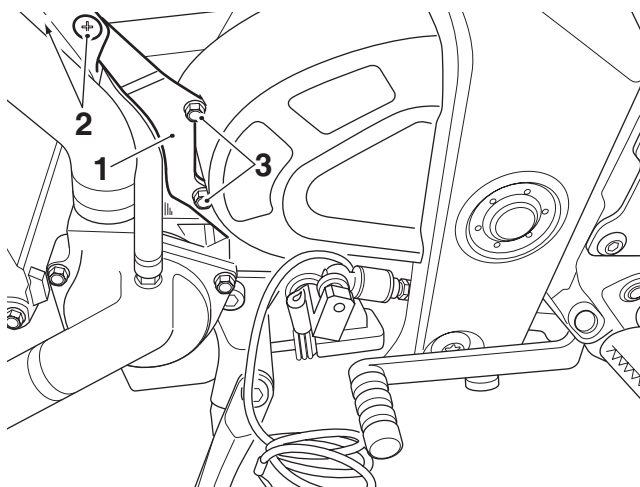

1. Bracket
2. Plastic fixings
3. Screws

19. Route the Quickshifter cable over the transmission linkage and up through the motorcycle frame to the area below the fuel tank, as shown below.

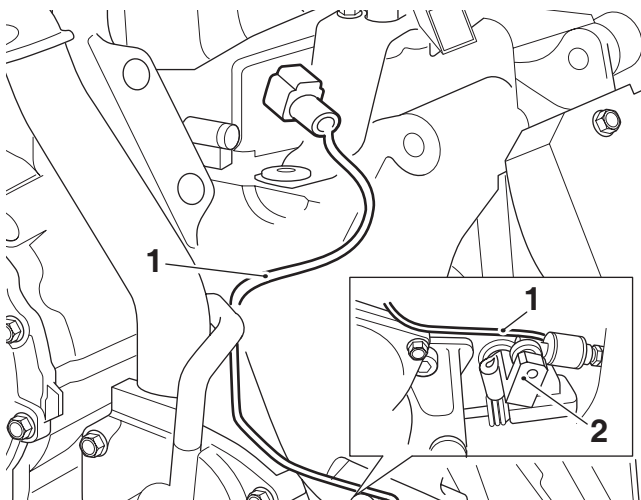

1. Quickshifter cable
2. Transmission linkage



Caution

A wiring harness or cable which becomes trapped, kinked or pinched during installation, or general motorcycle operation, may result in wiring harness damage and electrical malfunctions.

20. Refit the bracket to the left hand side of the frame and secure with the original plastic fixings and screws. Do not fully tighten the screws at this stage.

21. Ensure the Quickshifter cable is not trapped or pinched between the bracket and motorcycle frame. Tighten the screws to **7 Nm**.

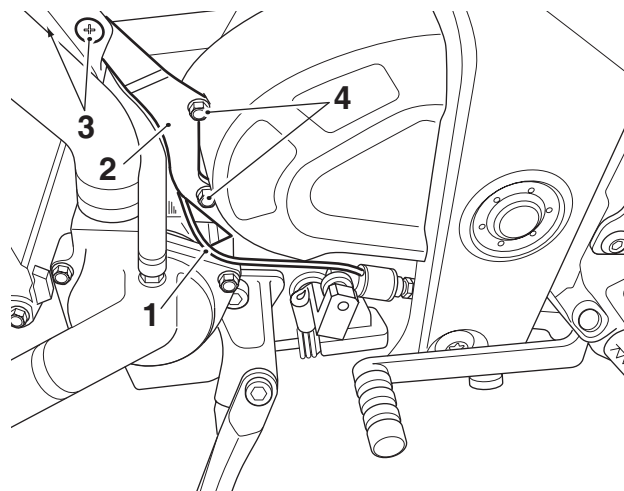

1. Quickshifter cable
2. Bracket
3. Plastic fixings
4. Screws

Note:

- The main harness connector for the Quickshifter is located in the area below the fuel tank.

22. Remove the blanking plug from the main harness connector and plug in the Quickshifter connector.

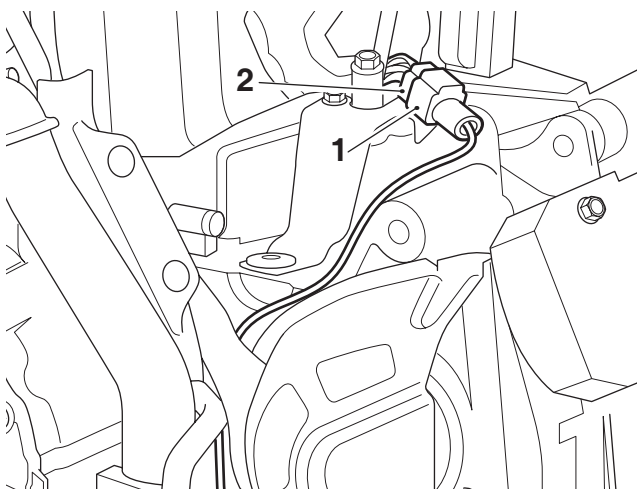

1. Quickshifter connector
2. Main harness connector

23. Ensure there is not excessive Quickshifter cable extending to the outside of the motorcycle, any excess cable should be tucked into the area below the fuel tank.

24. Secure the Quickshifter cable to the water pump hose using the cable clip provided, as shown below.

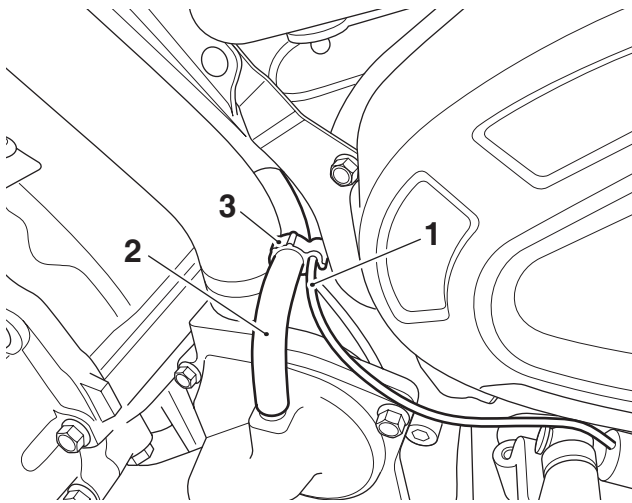

1. Quickshifter cable
2. Water pump hose
3. Cable clip

25. Refit the fuel tank, as described in the Service Manual.
26. Refit the seat, as described in the Service Manual.
27. Reconnect the battery, positive (red) lead first and tighten the battery terminals to **4.5 Nm**.
28. Refit the front panel to the fuel tank, as described in the Service manual.

Speed Triple S from VIN 867685, Speed Triple RS

Note:

- **The correct engine calibration must be downloaded to the motorcycle ECU prior to starting the engine. This information can be found on the 'Triumph Online' dealer web site.**
29. Connect the Triumph Diagnostic Tool and download the correct engine calibration with the Quickshifter enabled to the ECU following the procedure on the 'Triumph Online' dealer web site.
 30. Fully shut down the motorcycle, then switch the ignition back on.
 31. Enable the Quickshifter on the instrument panel, as described in the Service Manual.
 32. Ride the motorcycle for 10 seconds in each gear. The instruments will display a 'Transmission Warning' message until the gear positions are adapted.

All Models

Note:

- **If it is necessary to adjust the gear pedal angle at any point after fitting the Quickshifter, follow the steps below.**
33. Remove the front panel from the fuel tank, as described in the Service Manual.
 34. Disconnect the battery, negative (black) lead first.
 35. Remove the seat, as described in the Service Manual.
 36. Remove the fuel tank, as described in the Service Manual.
 37. Remove the Quickshifter cable from the cable clip.
 38. Unplug the Quickshifter connector from the main harness connector and feed the cable back through the frame.
 39. Loosen rear ball joint lock nut on the Quickshifter assembly.
 40. Turn the Quickshifter assembly to achieve the desired pedal angle. Note, the Quickshifter assembly must be turned in complete revolutions to ensure the Quickshifter cable is positioned at the bottom.
 41. Continue from step 17.

Operational Instructions:

All Kits

- Due to the competition nature of the Quickshifter, it is necessary to use a "positive" pedal force to ensure a smooth gear change.
- The Quickshifter assembly will trigger a momentary engine cut to allow the gear to engage, without closure of the throttle or operation of the clutch.
- The Quickshifter will not operate if the clutch is applied.
- The Quickshifter will only operate at engine speeds greater than 2500 rpm.
- Use the clutch when selecting first gear from neutral. The Quickshifter will not operate when changing from neutral to first gear.
- The Quickshifter will not operate when in 6th gear if an up-change is attempted by mistake.

Note:

- **A9930428**
The Quickshifter will only operate for up-changes, the clutch must be used for down-changes.
- **A9930469**
The Quickshifter will operate for up and down-changes.



Warning

If, after fitting this accessory kit, you have any doubt about the performance of any aspect of the motorcycle, contact an authorised Triumph dealer and do not ride the motorcycle until the authorised dealer has declared it fit for use. Riding a motorcycle when there is any doubt as to any aspect of the performance of the motorcycle may result in loss of control of the motorcycle leading to an accident.



Warning

Never ride an accessory-equipped motorcycle at speeds above 80 mph (130 km/h).

The presence of accessories will cause changes in the stability and handling of the motorcycle. Failure to allow for changes in motorcycle stability may lead to loss of control or an accident.

Remember that the 80 mph (130 km/h) limit will be reduced by the fitting of non-approved accessories, incorrect loading, worn tyres, overall motorcycle condition and poor road or weather conditions.



Warning

The motorcycle must not be operated above the legal road speed limit except in closed-course conditions.



Warning

Only operate this Triumph motorcycle at high speed in closed-course, on-road competition or on closed-course racetracks. High-speed operation should only be attempted by riders who have been instructed in the techniques necessary for high speed riding and are familiar with the motorcycle's characteristics in all conditions.

High-speed operation in any other circumstances is dangerous and will lead to loss of motorcycle control and an accident.